



## XFP Optical Receiver, 80km Reach FX-R192-ZRC

### Features

- ◆ Supports 9.95Gb/s to 11.1Gb/s bit rates
- ◆ Hot-pluggable XFP footprint
- ◆ Maximum link length of 80km with SMF
- ◆ APD ROSA receiver
- ◆ XFP MSA package with duplex LC connector
- ◆ No reference clock required
- ◆ Compatible with RoHS
- ◆ +3.3V power supply
- ◆ Power dissipation <0.7W
- ◆ Built-in digital diagnostic functions
- ◆ Temperature range 0°C to 70°C



### Applications

- ◆ SDH STM I-64.1 at 9.953Gbps
- ◆ 10GBASE-LR/LW 10G Ethernet
- ◆ 1200-SM-LL-L 10G Fibre Channel
- ◆ 10GE over G.709 at 11.09Gbps
- ◆ OC192 over FEC at 10.709Gbps
- ◆ Other optical links, up to 11.1Gbps

### Description

FIBERER FX-R192-ZRC is compliant with the 10G Small Form-Factor Pluggable (XFP) Multi-Source Agreement (MSA), supporting data-rate of 10.3125Gbps(10GBASE-LR) or 9.953Gbps 10GBASE-LW), and transmission distance up to 10km on SMF.

The receiver module only use a APD photodiode. Work temperature range of 0°C to +70°C and offers optimum heat dissipation and excellent electromagnetic shielding thus enabling high port densities for 10 GbE systems.

### Absolute Maximum Ratings



Parameter	Symbol	Min	Max	Unit	Ref.
Storage Ambient Temperature Range		-40	+85	°C	
Powered case Temperature Range		0	+75	°C	
Operating Relative Humidity	RH		80	%	
Supply Voltage Range @ 3.3V	Vcc3	-0.5	4.0	V	

Any stress beyond the maximum ratings can result in permanent damage. The device specifications are guaranteed only under the recommended operating conditions.

### Electrical Characteristics

Parameter	Symbol	Min	Typ	Max	Unit	Note
Operating Case Temperature Range	$T_c$	0		+70	°C	
Power Supply Voltage @ 3.3V	Vcc3	3.13	3.3	3.47	V	
Module total power	P			0.7	W	
Receiver						
Differential data output swing	Vout,pp	500		850	mV	
Data output rise time	$t_r$			38	ps	2
Data output fall time	$t_f$			38	ps	2
LOS Fault	$V_{LOS\ fault}$	Vcc - 0.5		$V_{CCHOST}$	V	3
LOS Normal	$V_{LOS\ norm}$	GND		GND+0.5	V	3
Power Supply Rejection	PSR	See Note 3 below				4

**Notes:**

1. After internal AC coupling.
2. 20 – 80 %
3. Loss Of Signal is open collector to be pulled up with a 4.7k – 10kohm resistor to 3.15 – 3.6V. Logic 0 indicates normal operation; logic 1 indicates no signal detected.
4. Per Section 2.7.1. in the XFP MSA Specification.

### Optical Characteristics

Parameter	Symbol	Min	Typ	Max	Unit	Ref.
-----------	--------	-----	-----	-----	------	------



Receiver						
Receiver Sensitivity	RSENS			-24	dBm	2
Receiver Sensitivity in OMA	RSENS			-23	dBm	2
Maximum Input Power	PMAX			-7	dBm	
Optical Center Wavelength	$\lambda_C$	1528		1564	nm	
LOS De-Assert	LOS <sub>D</sub>			-27	dBm	
LOS Assert	LOS <sub>A</sub>	-34			dBm	
LOS Hysteresis		0.5			dB	

Notes:

- 1, PRBS 2<sup>31</sup>-1 test pattern @10.3125Gbps.
- 2, PRBS 2<sup>31</sup>-1 test pattern @10.3125Gbps, BER≤10<sup>-12</sup>.

### Pin Descriptions

Pin	Logic	Symbol	Name/Description	Ref
1		GND	Module Ground	1
2		VEE5	Optional -5.2 Power Supply – <b>Not required</b>	
3	LVTTL-I	Mod-Desel	Module De-select; When held low allows the module to respond to 2-wire serial interface commands	
4	LVTTL-O	Interrupt	Interrupt (bar); Indicates presence of an important condition which can be read over the serial 2-wire interface	2
5	LVTTL-I	TX_DIS	Transmitter Disable; Transmitter laser source turned off	
6		VCC5	+5 Power Supply – <b>Not required</b>	
7		GND	Module Ground	1
8		VCC3	+3.3V Power Supply	
9		VCC3	+3.3V Power Supply	
10	LVTTL-I	SCL	Serial 2-wire interface clock	2
11	LVTTL-I/O	SDA	Serial 2-wire interface data line	2
12	LVTTL-O	Mod_Abs	Module Absent; Indicates module is not present. Grounded in the module.	2
13	LVTTL-O	Mod_NR	Module Not Ready;	2
14	LVTTL-O	RX_LOS	Receiver Loss of Signal indicator	2
15		GND	Module Ground	1
16		GND	Module Ground	1
17	CML-O	RD-	Receiver inverted data output	
18	CML-O	RD+	Receiver non-inverted data output	
19		GND	Module Ground	1
20		VCC2	+1.8V Power Supply – <b>Not required</b>	
21	LVTTL-I	P_Down/R_ST	Power Down; When high, places the module in the low power stand-by mode and on the falling edge of P_Down initiates a module reset	



			Reset; The falling edge initiates a complete reset of the module including the 2-wire serial interface, equivalent to a power cycle.	
22		VCC2	+1.8V Power Supply – <b>Not required</b>	
23		GND	Module Ground	1
24	PECL-I	RefCLK+	Reference Clock non-inverted input, AC coupled on the host board – <b>Not required</b>	3
25	PECL-I	RefCLK-	Reference Clock inverted input, AC coupled on the host board – <b>Not required</b>	3
26		GND	Module Ground	1
27		GND	Module Ground	1
28	CML-I	TD-	Transmitter inverted data input	
29	CML-I	TD+	Transmitter non-inverted data input	
30		GND	Module Ground	1

**Notes:**

1. Module circuit ground is isolated from module chassis ground within the module.
2. Open collector; should be pulled up with 4.7k – 10k ohms on host board to a voltage between 3.15V and 3.6V.
3. A Reference Clock input is not required.

**Hostboard Connector Pinout**

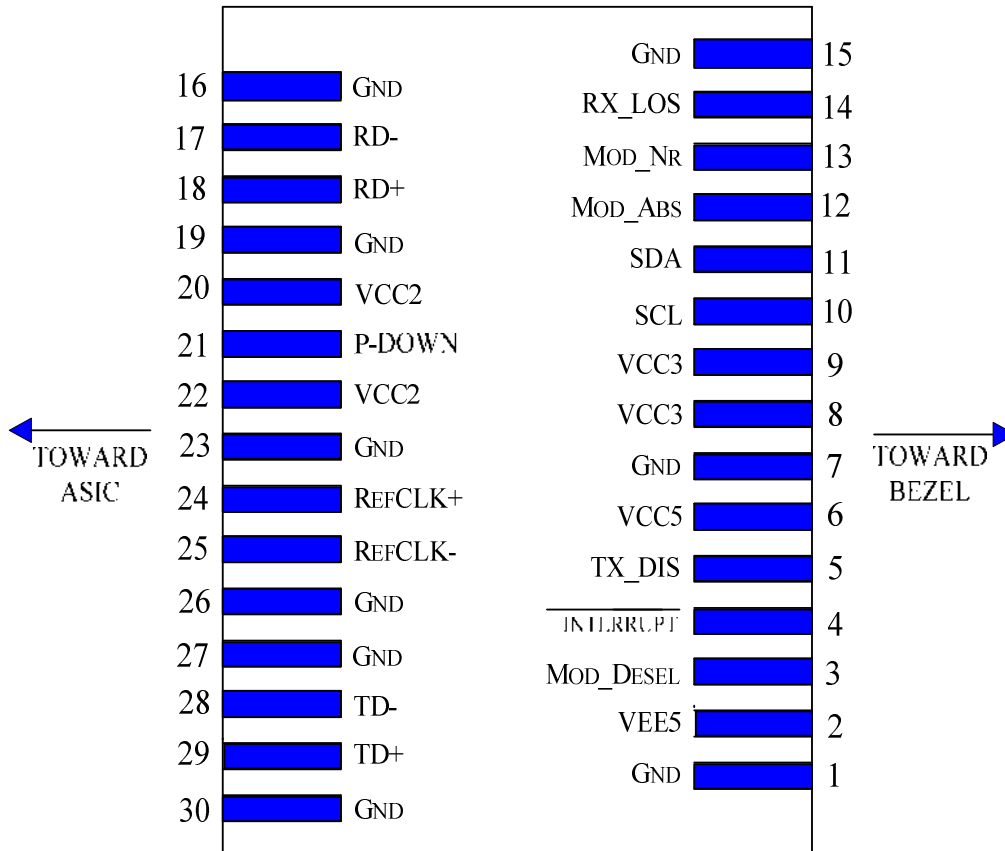

### General Specifications

Parameter	Symbol	Min	Typ	Max	Units	Ref.
Bit Rate	BR	9.95		11.1	Gb/s	1
Bit Error Ratio	BER			10 <sup>-12</sup>		2
Max. Supported Link Length	L <sub>MAX</sub>		80		km	1

**Notes:**

- SONET OC-192 SR-1, SDH STM I-64.1, 10GBASE-LR/LW, 1200-SM-LL-L
- Tested with a 2<sup>31</sup> - 1 PRBS

### Management Interface

The transceivers provide serial ID memory contents and diagnostic information about the present operating conditions by the 2-wire serial interface (SCL, SDA).



The Module provides diagnostic information about the present operating conditions. The transceiver generates this diagnostic data by digitization of internal analog signals. Alarm/warning threshold data is written during device manufacture. Received power monitoring, transmitted power monitoring, bias current monitoring, supply voltage monitoring and temperature monitoring all are implemented.

The digital diagnostic memory map specific data field defines as following.

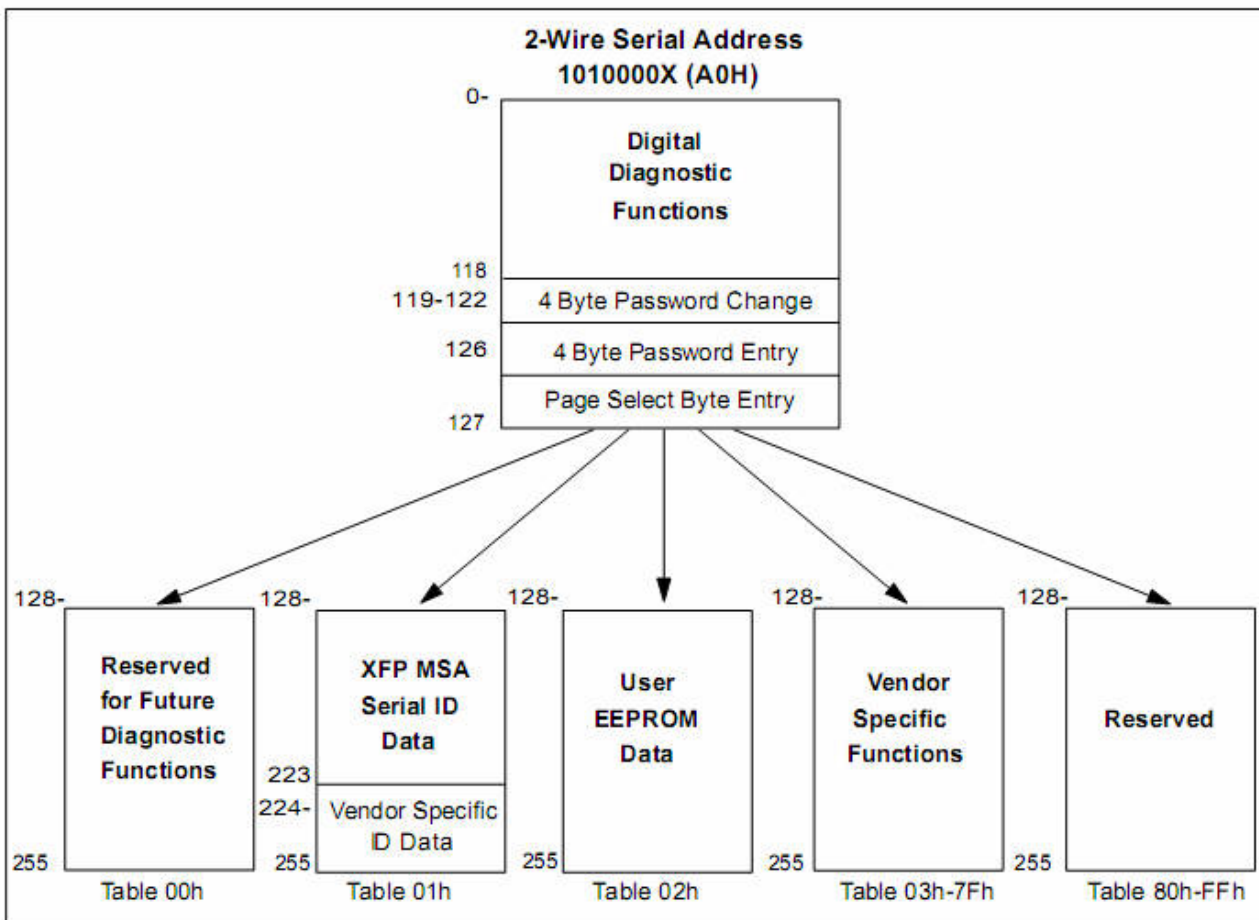

## Recommended Host Board Power Supply Circuit

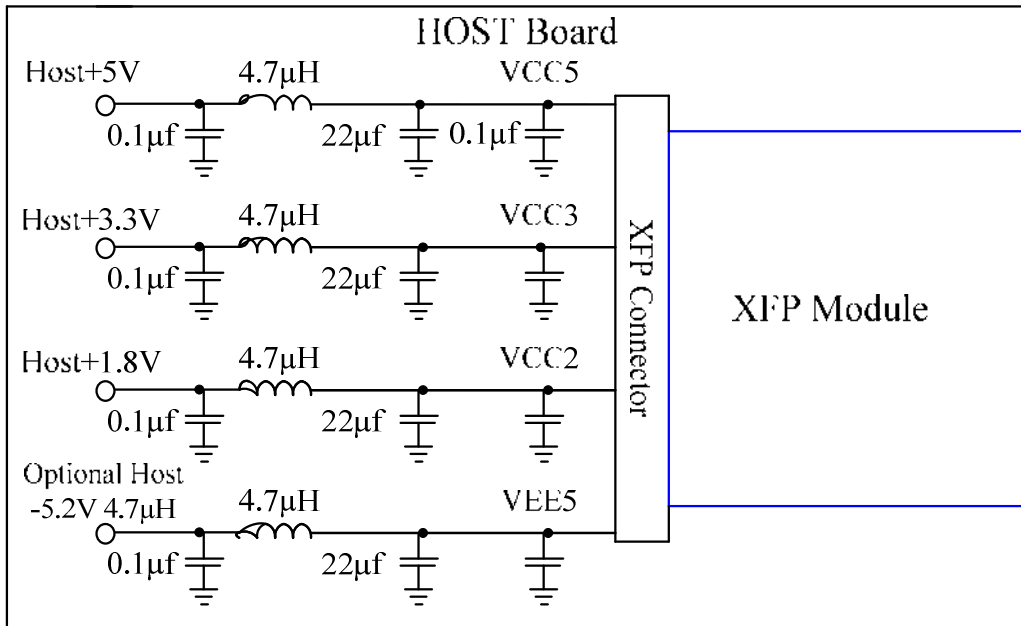

### Recommended High-speed Interface Circuit

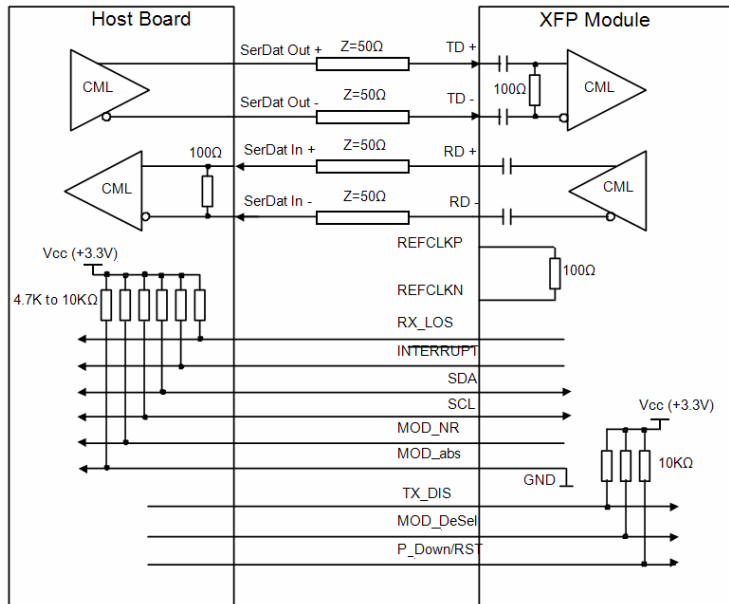

### Mechanical Specifications

XFP transceivers are compliant with the dimensions defined by the XFP Multi-Sourcing Agreement (MSA).



Fiberer Global Tech Ltd  
[sales@fiberer.com](mailto:sales@fiberer.com)

NO.1 Service NO.1 Quality  
[www.transceivermodule.com](http://www.transceivermodule.com)

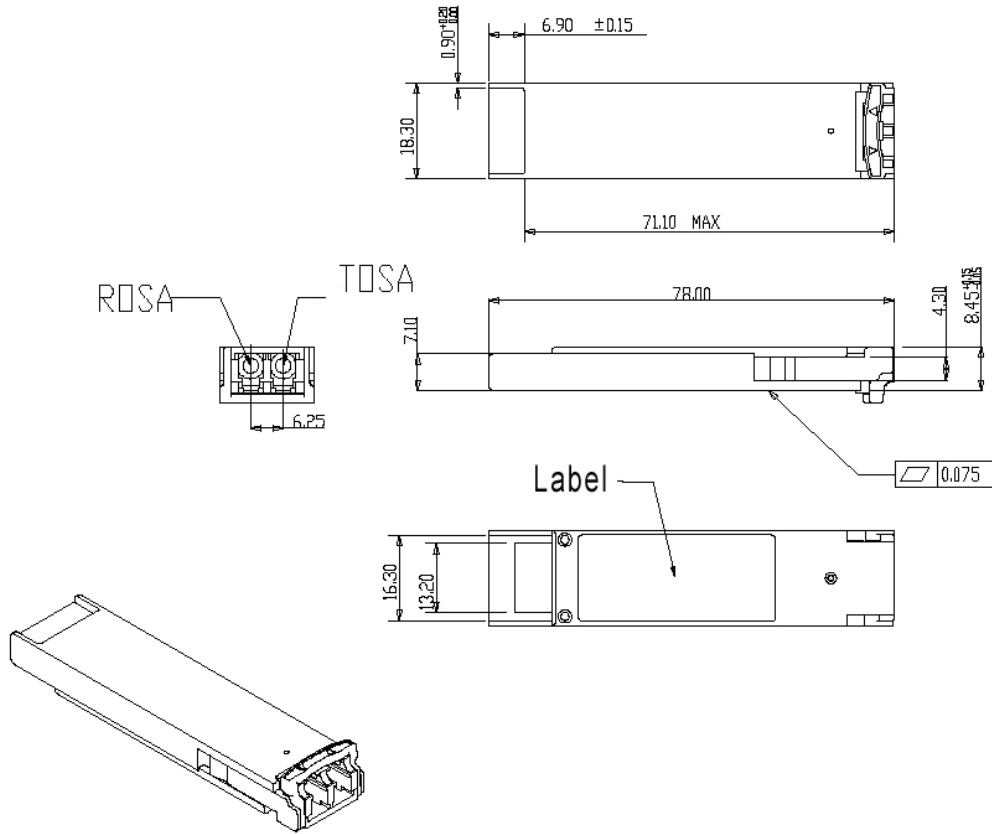

## Ordering information

Part Number	Product Description
FX-R192-ZRC	APD, 10Gbps, 80km, 0°C ~ +70°C





Fiberer Global Tech Ltd  
[sales@fiberer.com](mailto:sales@fiberer.com)

NO.1 Service NO.1 Quality  
[www.transceivermodule.com](http://www.transceivermodule.com)

**Company name:** Fiberer Global Tech Ltd.

**Address:** C-1703, JiaNanMeiDi, Shennan Road 12031 with Nanxin Road  
Converged,Nantou,Nanshan District, Shenzhen 518052,  
China

**Telephone:** +86-755-3320-1588  
**Fax:** +86-755-3320-1568

**Email:** [sales@fiberer.com](mailto:sales@fiberer.com) ; [TransceiverModule@163.com](mailto:TransceiverModule@163.com)

**Website:** <http://www.transceivermodule.com>